

INSTALLATION INSTRUCTIONS

ACB1

ONE ZONE AMPLIFIED CONNECTING BLOCK

The Model **ACB1** is an Amplified Connecting Block that permits up to 10 single or 10 dual emitters (or any combination thereof) to be driven directly at high or low power levels. The ACB1 interfaces all Sonance IR Receivers to the emitters along with a power supply in an infrared repeater system. A floating terminal is provided for "STATUS" line connections.

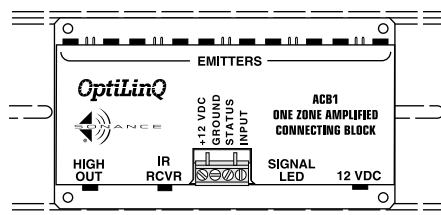

Fig. 1: ACB1 Amplified Connecting Block
Mounted in 3" SNAPTRACK®
(SNAPTRACK is a registered trademark of AUGAT)

SPECIFICATIONS

- Inputs: 1 - Screw type 4-terminal plug-in.
1 - IR Receiver "IR RCVR" 3.5mm mini stereo jack.
- Outputs: 10 - Emitter ports (3.5mm mini mono jacks) parallel driven. 1 - High Level IR signal output port (3.5mm mini mono jack).
- Use of included jumpers connect either a 100 or a 470-Ohm resistor in series with each emitter output for high or low power operation.
- **E1, E2, VE1 & VE2** Mini Emitters may be used in any combination.
- Power requirements: 12 volts DC. Uses **PS1** or **PS2** Power Supplies.
- 2.1 mm coaxial power jack.
- Dimensions: 5 3/8" W x 3" D x 7/8" H.

INSTALLATION

Fig. 2 illustrates a typical installation of a **ACB1** in an IR repeater system. A variety of Sonance IR Receivers and a keypad are shown. When configuring a system, please keep the following items in mind:

1. More IR receivers may be wired in parallel, in the same manner as shown, up to a maximum of twelve. More than twelve is not recommended because IR noise picked up by the many IR receivers may cause erratic operation and reduce remote control range.
2. Be sure to connect the +12V, Output and GND of each IR receiver and keypad to the respective +12VDC, INPUT and GND of the connecting block as shown.
3. Power Supply Requirements. You may combine many Sonance IR receivers, controllers and emitters in a system. Having sufficient power supply voltage and current available is critical for proper operation. Be sure to take the following factors into consideration:
 - a. The maximum current for proper operation from a **PS1** Power Supply is 120 mA (milliamps).
 - b. The maximum current from a **PS2** Power Supply is 1000 mA.
 - c. Most IR receivers draw 2 mA without signal and 10 mA with signal (check specs. on actual model).
 - d. Each emitter draws 5 mA in low power mode and 15 mA in high power mode.
 - e. When using combinations of these devices, add up their currents, then choose the power supply according to the maximum current capabilities as noted above!
 - f. To avoid current "hogging", never connect regulated supplies, such as the **PS1** and **PS2**, in parallel!

CAUTION: Do not use unregulated 12V power supply adapters from other manufacturers. These may deliver excessive voltage to the IR receivers and cause them to “latch-up”. When this occurs, the “talk-back” LEDs and **VE1** emitters (if used) will stay on continuously!

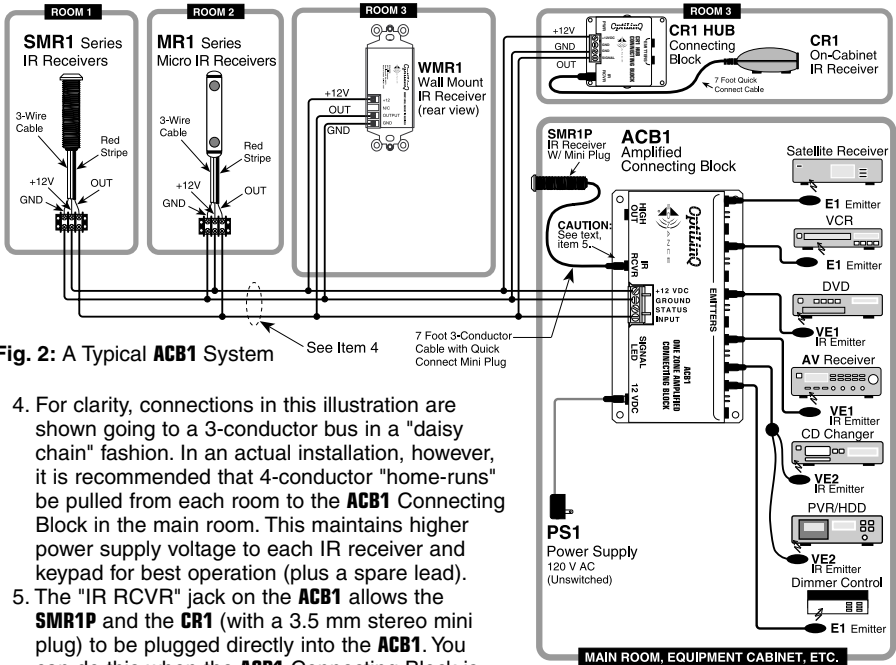

Fig. 2: A Typical ACB1 System

4. For clarity, connections in this illustration are shown going to a 3-conductor bus in a "daisy chain" fashion. In an actual installation, however, it is recommended that 4-conductor "home-runs" be pulled from each room to the **ACB1** Connecting Block in the main room. This maintains higher power supply voltage to each IR receiver and keypad for best operation (plus a spare lead).
5. The "IR RCVR" jack on the **ACB1** allows the **SMR1P** and the **CR1** (with a 3.5 mm stereo mini plug) to be plugged directly into the **ACB1**. You can do this when the **ACB1** Connecting Block is within reach of the IR receiver's cable -- such as when installing the **SMR1P** in a cabinet where the controlled equipment is behind closed doors.

CAUTION: Plug only Sonance IR Receivers equipped with a stereo mini plug into the IR RCVR jack. Do not plug in emitters or other devices. To do so will destroy emitters and damage power supplies!

Emitter Output Ports - High and Low Power Settings

The emitter ports are driven in parallel with a choice of either a 100 Ohm or a 470 Ohm resistor connected in series with each port. The 100 Ohm choice delivers high power output and the 470 Ohm setting is lower power. The high power setting is achieved by plugging a small jumper (10 are supplied) onto the pair of pins adjacent to the desired emitter port, as shown in Fig. 3 below. The low power option is with the jumper removed.

NOTE: The **ACB1**'s are shipped from the factory with the jumpers removed (low power position).

Consider the following factors when choosing high or low power modes:

1. In the majority of cases, when you mount an emitter on the IR sensor window of the controlled device, you would use the low power mode (jumpers removed). This prevents overload of high gain sensor circuits and allows proper operation.
2. The high power mode may be used in installations where you mount the emitters on an

adjacent cabinet wall or door a short distance from the unit's sensor. Another instance is when you place an emitter inside the device, but cannot place it close to the IR sensor. In such cases, you may need the extra power of the high power mode to blast through printed circuit boards or around chassis structures. In addition, when using the lower output **VE1** and **VE2** Blink IR's, you may need the high power mode for some devices that have less sensitive IR sensors.

- The resistors also provide current sharing to each emitter and allow the use of dual emitters in combination with single emitters. You may, therefore, connect any combination of emitter models **E1**, **VE1**, **E2** & **VE2** in the same system, as illustrated in Fig. 2, to drive the desired number of devices.

When using less than 10 of the emitter ports, you may plug into any of them without regard to order.

Fig. 3: Emitter Power - Jumper Placement

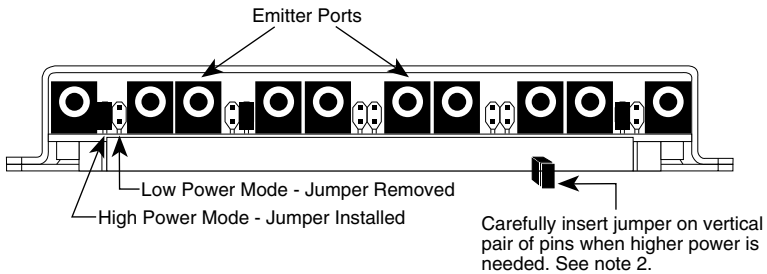

IMPORTANT NOTE: When using lengths greater than 250 ft.) of inter-room shielded cable, it may be necessary to connect a 470 Ohm 1/8 watt resistor between input terminals of Sonance connecting blocks (CB1, CB2Z, ACB1), zone controllers, etc.

Fig. 4: 470 Ohm Capacitance Discharge Resistor

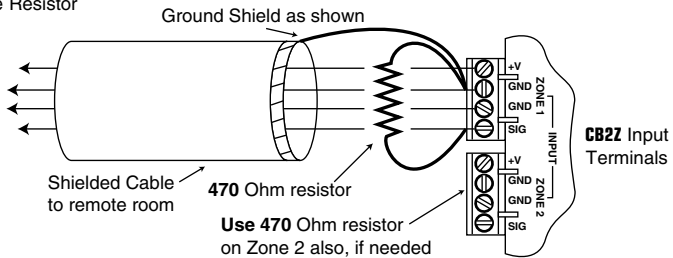

MOUNTING: The ACB1 can be conveniently mounted to a wall or shelf by using screws or mounted into a 3" SNAPTRACK. (SNAPTRACK is a registered trademark of AUGAT)